



Why ELEVATE[™] Porcelain Floor?

ELEVATE[™] Porcelain Raised Access Floor from Global IFS conveys an elegant and sophisticated image in areas such as entryways, lobbies, hallways and cafes that are key in reflecting your brand.

As with all Global IFS flooring products, ELEVATE[™] offers the highest level of adaptability. When your work environment needs to change as business needs change, our ELEVATE[™] Porcelain RAF delivers. It is perfect for high-traffic, commercial environments where access to utilities, easy reconfiguration, and quick replacement are priorities.

With a 1,600-lb. concentrated load rating, the ELEVATE[™] Porcelain Raised Access Floor will meet your toughest load requirements, while maintaining a design-forward impression in your key traffic areas.



Features & Advantages

- Frequent space changes are easy to facilitate; simply lift the access floor tiles and gain unrestricted access to underfloor utilities and building infrastructure.
- Reconfiguration and quick replacement if a tile is damaged.
- Tiles are easy for installers to move or reuse, or replace with a suction cup lifter.
- Many unique finishes that seamlessly match with your commercial interior décor.
- Matching tiles can be used for steps, ramps and wall base.
- Porcelain tiles can even be used to create brilliant outdoor patio and rooftop areas.



ELEVATE[™] Porcelain System

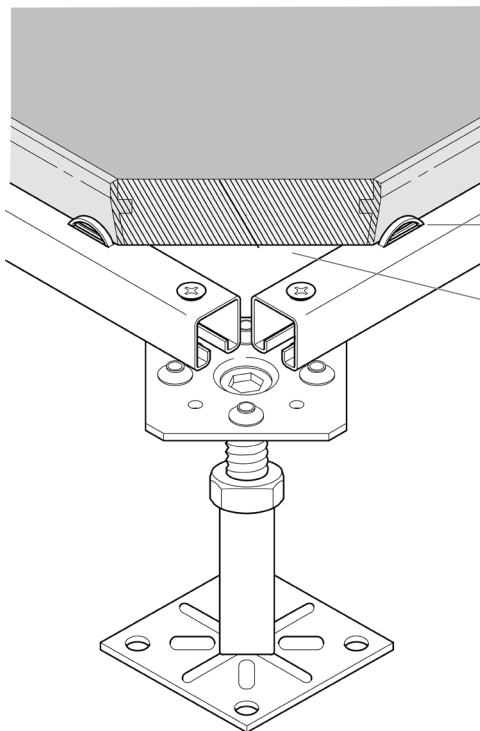

— Durable porcelain surface optimizes floor panel life.

— Self-Extinguishing, Sound-Minimizing Edge protects the panel from chipping or cracking as panels are moved for access under the floor.

— Built-in positioning tab on every stringer eliminates racking or skewing of panel grid.

— Full panel thickness rests on supporting understructure, eliminating structural vulnerability at panel edge and corner.